

DW2 ワイパーシール (NOK社:DWI互換品)

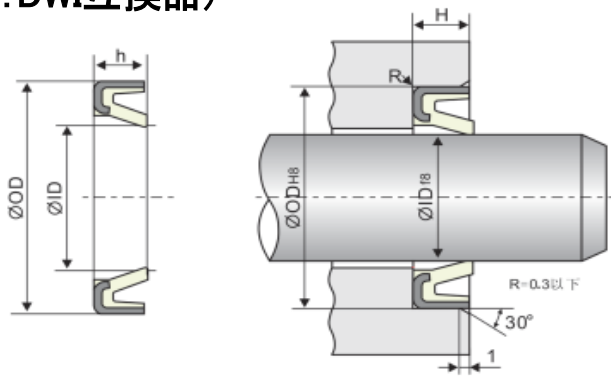

仕様	
材質	PU+STEEL
温度域	-40°C~100°C
速度	1m/s

単位:mm

商品コード	型番	ID	OD	h	H
1210-01172	DW2-040-52-7	40	52	7	7 ^{+0.5} _{+0.3}
1210-01174	DW2-042-52-8	42	52	8	8 ^{+0.5} _{+0.3}
1210-01176	DW2-045-57-7	45	57	7	7 ^{+0.5} _{+0.3}
1210-01178	DW2-050-60-7	50	60	7	7 ^{+0.5} _{+0.3}
1210-01179	DW2-050-62-7	50	62	7	7 ^{+0.5} _{+0.3}
1210-01180	DW2-055-69-8	55	69	8	8 ^{+0.6} _{+0.4}
1210-01190	DW2-060-74-8	60	74	8	8 ^{+0.6} _{+0.4}
1210-01200	DW2-065-79-8	65	79	8	8 ^{+0.6} _{+0.4}
1210-01210	DW2-070-84-8	70	84	8	8 ^{+0.6} _{+0.4}
1210-01220	DW2-075-89-8	75	89	8	8 ^{+0.6} _{+0.4}
1210-01230	DW2-080-90-7	80	90	7	7
1210-01240	DW2-080-94-8	80	94	8	8 ^{+0.6} _{+0.4}
1210-01245	DW2-080-95-7	80	95	7	7
1210-01250	DW2-085-99-8	85	99	8	8 ^{+0.6} _{+0.4}
1210-01260	DW2-090-104-8	90	104	8	8 ^{+0.6} _{+0.4}
1210-01264	DW2-095-109-8	95	109	8	8 ^{+0.6} _{+0.4}
1210-01266	DW2-095-110-7	95	110	7	7
1210-01270	DW2-100-114-8	100	114	8	8 ^{+0.6} _{+0.4}
1210-01280	DW2-105-121-9	105	121	9	9
1210-01290	DW2-110-126-9	110	126	9	9 ^{+0.6} _{+0.4}
1210-01295	DW2-120-135-7	120	135	7	7
1210-01300	DW2-120-136-9	120	136	9	9 ^{+0.6} _{+0.4}
1210-01310	DW2-130-146-9	130	146	9	9 ^{+0.6} _{+0.4}
1210-01320	DW2-140-160-10	140	160	10	10 ^{+0.6} _{+0.4}
1210-01330	DW2-150-170-10	150	170	10	10 ^{+0.6} _{+0.4}