

DI2 ワイパーシール (NOK社:DKI互換品)

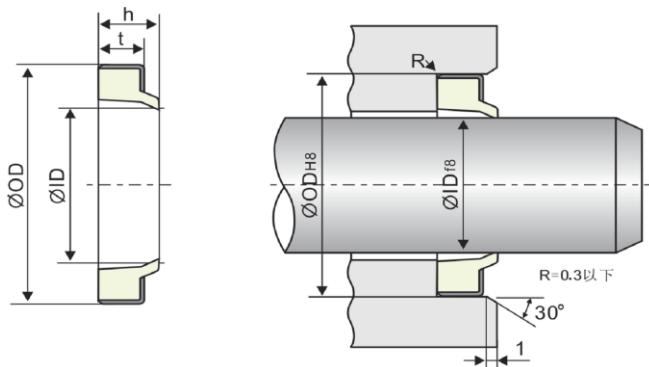

仕様	
材質	PU+STEEL
温度域	-35°C~100°C
速度	1m/s

単位: mm

商品コード	型番	ID	OD	t/h
	DI2-010-20	10	20	5/7
	DI2-012.5-23	12.5	23	5/7
	DI2-014-24	14	24	5/7
	DI2-015-25	15	25	5/7
	DI2-016-26	16	26	5/7
1210-02170	DI2-018-28	18	28	5/7
	DI2-018-30	18	30	6/9
1210-02180	DI2-020-32	20	32	6/9
	DI2-022.4-34.4	22.4	34.4	6/9
1210-02190	DI2-025-35	25	35	5/7
1210-02200	DI2-025-37	25	37	6/9
1210-02210	DI2-028-40	28	40	6/9
1210-02220	DI2-030-40	30	40	5/7
1210-02230	DI2-030-42	30	42	6/9
	DI2-031.5-44	31.5	44	7/10
1210-02240	DI2-032-42	32	42	5/8
	DI2-032-44	32	44	7/10
1210-02250	DI2-035-45	35	45	7/10
1210-02260	DI2-035-47	35	47	7/10
	DI2-035.5-47.5	35.5	47.5	7/10
	DI2-038-50	38	50	7/10
1210-02270	DI2-040-50	40	50	7/10
1210-02280	DI2-040-52	40	52	7/10
1210-02290	DI2-045-55	45	55	7/10
1210-02300	DI2-045-57	45	57	7/10
1210-02310	DI2-050-60	50	60	7/10
1210-02320	DI2-050-62	50	62	7/10
	DI2-053-67	53	67	8/11
1210-02330	DI2-055-65	55	65	7/10
1210-02340	DI2-055-69	55	69	8/11
	DI2-056-70	56	70	8/11
1210-02350	DI2-060-70	60	70	7/10
1210-02360	DI2-060-74- 8/11	60	74	8/11
	DI2-060-74- 8/13	60	74	8/13
	DI2-063-77	63	77	8/11
	DI2-064-78	64	78	8/11

DI2 ワイパーシール (NOK社:DKI互換品)

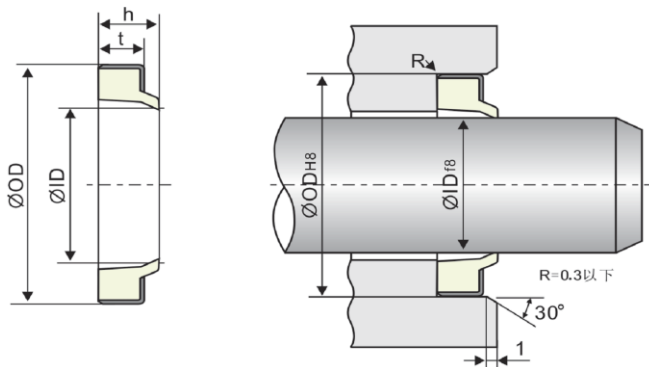

仕様	
材質	PU+STEEL
温度域	-35°C~100°C
速度	1m/s

単位: mm

商品コード	型番	ID	OD	t/h
1210-02370	DI2-065-75	65	75	7/10
1210-02380	DI2-065-79	65	79	8/11
	DI2-067-81	67	81	8/11
1210-02390	DI2-070-80	70	80	7/10
1210-02400	DI2-070-84- 8/11	70	84	8/11
	DI2-070-84- 8/13	70	84	8/13
	DI2-071-85	71	85	8/11
1210-02410	DI2-075-85	75	85	7/10
	DI2-075-88- 7/9.5	75	88	7/9.5
1210-02420	DI2-075-89- 8/11	75	89	8/11
	DI2-075-89- 8/13	75	89	8/13
1210-02430	DI2-080-90	80	90	7/10
	DI2-080-93	80	93	7/9.5
1210-02440	DI2-080-94- 8/11	80	94	8/11
	DI2-080-94- 8/13	80	94	8/13
1210-02450	DI2-085-95	85	95	7/10
1210-02460	DI2-085-99- 8/11	85	99	8/11
	DI2-085-99- 8/13	85	99	8/13
1210-02470	DI2-090-100	90	100	7/10
1210-02480	DI2-090-104- 8/11	90	104	8/11
	DI2-090-104- 8/13	90	104	8/13
1210-02490	DI2-095-109- 8/11	95	109	8/11
	DI2-095-109- 8/13	95	109	8/13
1210-02500	DI2-100-110	100	110	7/10
1210-02510	DI2-100-114- 8/11	100	114	8/11
	DI2-100-114- 8/13	100	114	8/13
1210-02520	DI2-105-121- 9/12	105	121	9/12
	DI2-105-121- 9/15	105	121	9/15
1210-02530	DI2-110-120	110	120	7/10
1210-02540	DI2-110-126	110	126	9/12
1210-02550	DI2-115-131- 9/12	115	131	9/12
	DI2-115-131- 9/15	115	131	9/15
1210-02560	DI2-120-130	120	130	7/10
1210-02570	DI2-120-136	120	136	9/12
	DI2-125-141	125	141	9/12
1210-02580	DI2-130-146	130	146	9/12
1210-02590	DI2-140-160	140	160	10/14

DI2 ワイパーシール (NOK社:DKI互換品)

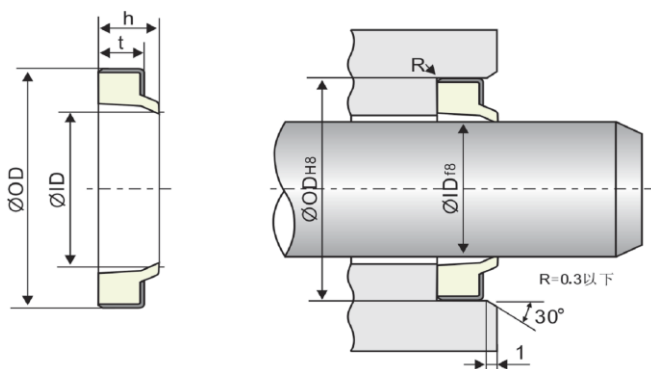

仕様	
材質	PU+STEEL
温度域	-35°C~100°C
速度	1m/s

単位: mm

商品コード	型番	ID	OD	t/h
1210-02600	DI2-150-170	150	170	10/14
1210-02610	DI2-160-180	160	180	10/14
	DI2-170-190	170	190	10/14
	DI2-180-205	180	205	12/17